

SECTION A-A

All sitting heights measured without load - a variation may occur depending on the load due to contraction of gas-struts, springs, upholstery and third part equipment.
 All information herein contained is subject to change without notice unless under contractual configuration control.
 Please consult Norsap if dimensions are critical or a certified drawing is required.

www.norsap.no

Chair interface:

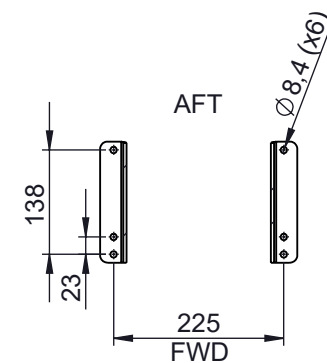

SECTION B-B
 SCALE 1 : 10

Weight: 18.5 w/o seat and backrest cushions



Mjåvannsvegen 45/47
 NO 4626 Kristiansand (Norway)

Description:

150 - Explore Performance - C5

Art.-No.:
 1010

Date:
 14.02.2023

Revision:
 PROTO 2